

CUSTOMER PART No.	CUSTOMER	CAN ART STD.	DIE No.
			EH05573
DESCRIPTION	3" x 3" x 0.188" THK. SQ. TUBE		PROPOSAL No. H-6506

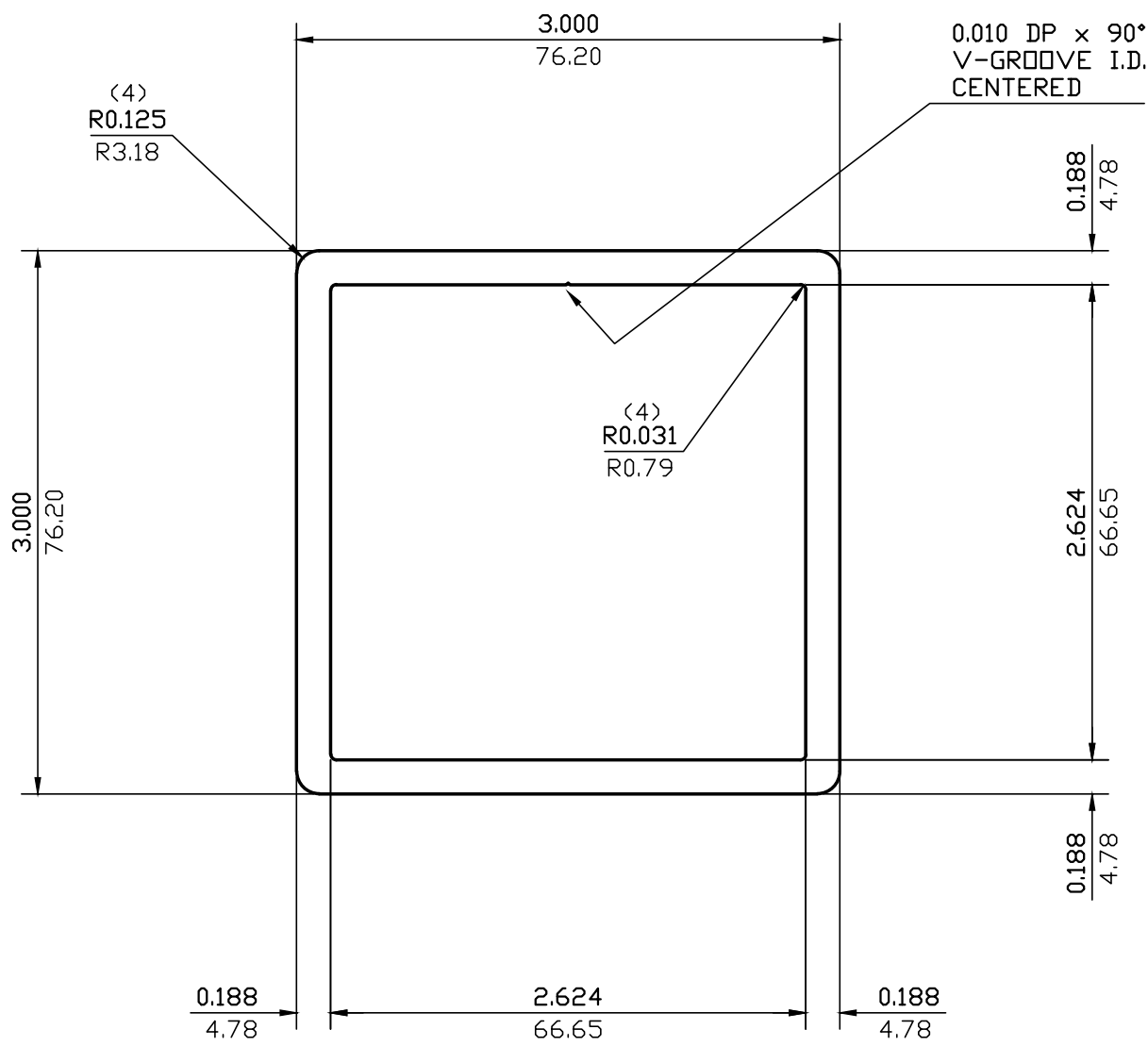

NOTE: BREAK ALL CORNERS WITH 0.015" (.38 MM) RADIUS UNLESS OTHERWISE NOTED. STANDARD TOLERANCES TO APPLY UNLESS OTHERWISE SPECIFIED.

WALL THICKNESS 0.188 (4.78) EXCEPT AS SHOWN

DATE	REV	DESCRIPTION	BY
EST.AREA	2.102	IN. ²	EST.AREA 1356
EST.WT.	2.522	LBS/FT.	EST.WT. 3.754
EST.PER.	22.236	IN.	EST.PER. 564.8
OUT PER.	11.785	IN.	OUT PER. 299.3
C.C.D.	4.139	IN.	C.C.D. 105
FACTOR	9	FINISH	M/F
CKD BY	SCALE 1:1	ALLOY & TEMP.	6063
		DWN BY	C.P.
		DATE	05/28/97

CAN ART

85 PARKSHORE DRIVE
BRAMPTON, ONT L6T 5M1
TEL. NO. (905) 791-1464
FAX NO. (905) 791-9151
E-MAIL: canart@canart.com

ALUMINUM EXTRUSION INC.

THIS DRAWING IS NOT NECESSARILY A COPY OF YOUR ORIGINAL. PLEASE APPROVE DIMENSIONS AND TOLERANCES INDICATED. CAN ART ASSUMES NO RESPONSIBILITY EITHER TECHNICAL OR LEGAL FOR HAVING THIS SHAPE MADE. THE CUSTOMER AGREES TO FULLY PROTECT CAN ART ALUMINUM FROM CLAIMS OF OTHERS RESULTING FROM THIS SHAPE.

SIGNED: _____ DATE: _____